

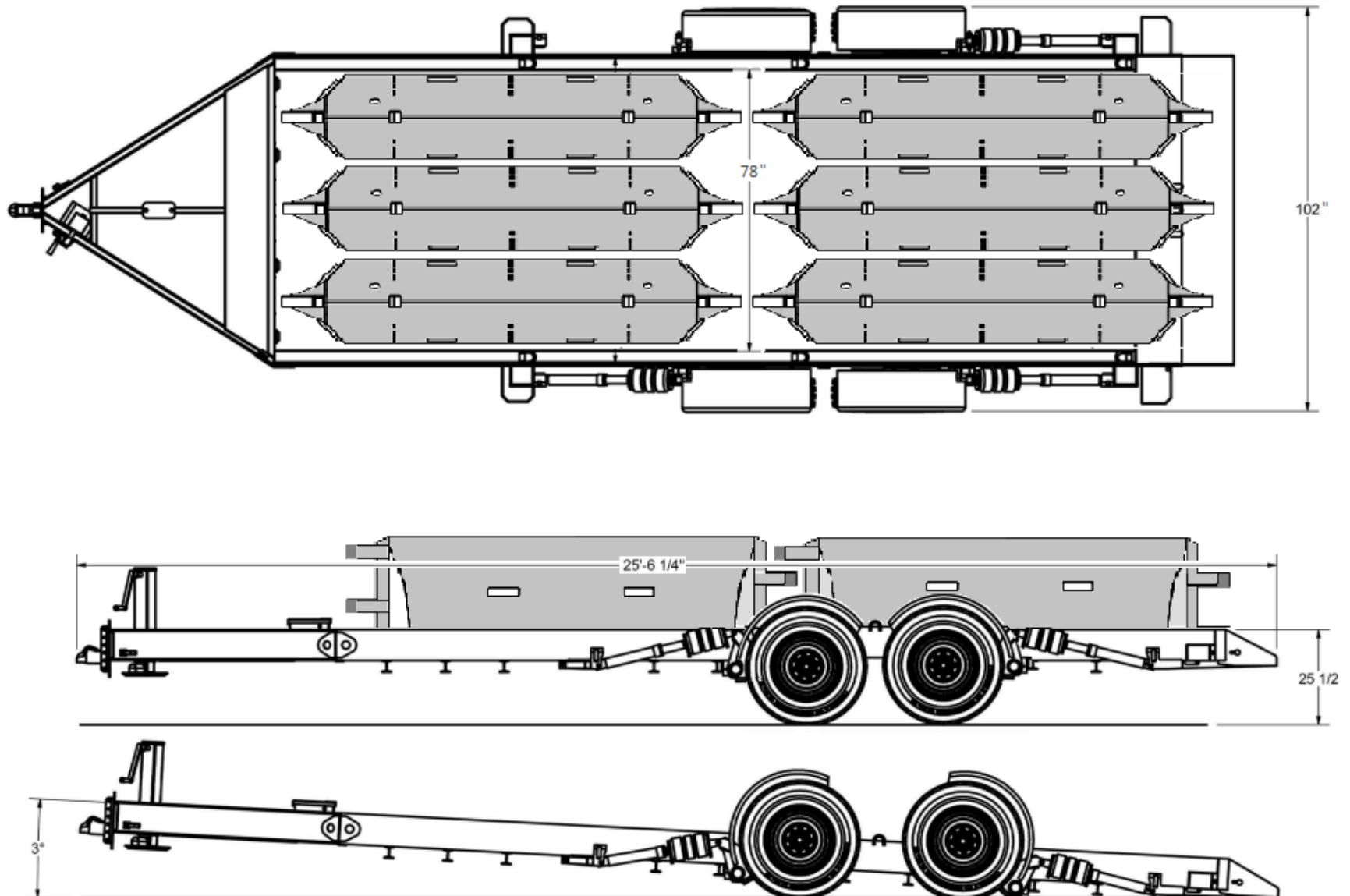

Mobile Defense Barrier System

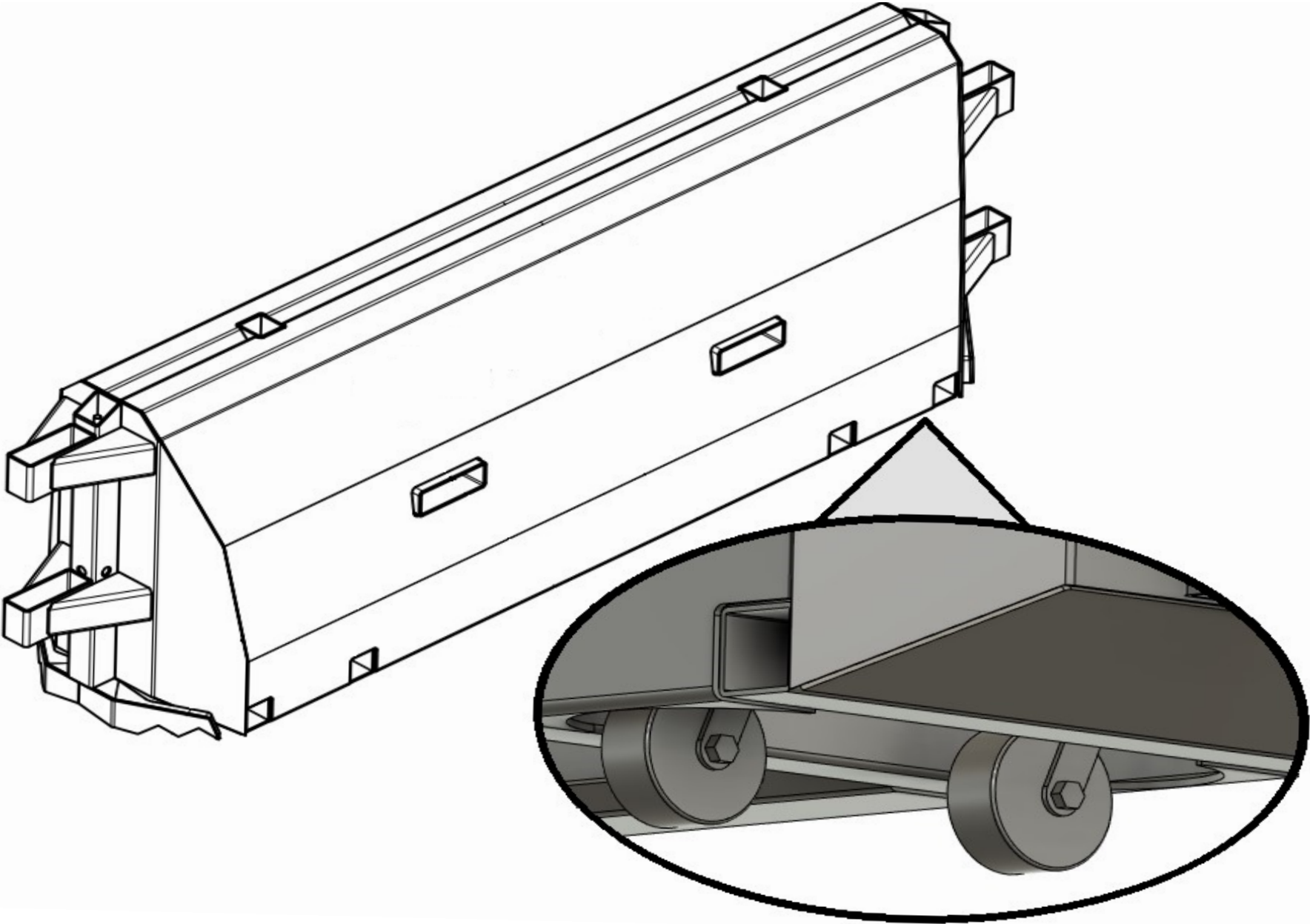

MODEL: 1350-RVB
1350 LB. ROLLING MOBILE VEHICLE STEEL BARRIER
MANUFACTURED BY: K12 DEFENSE - MESA, AZ



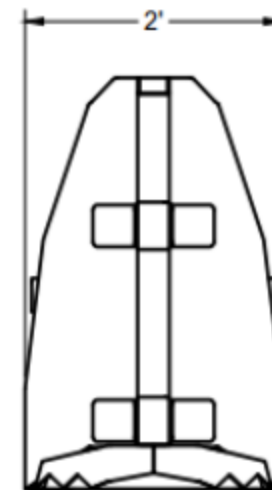
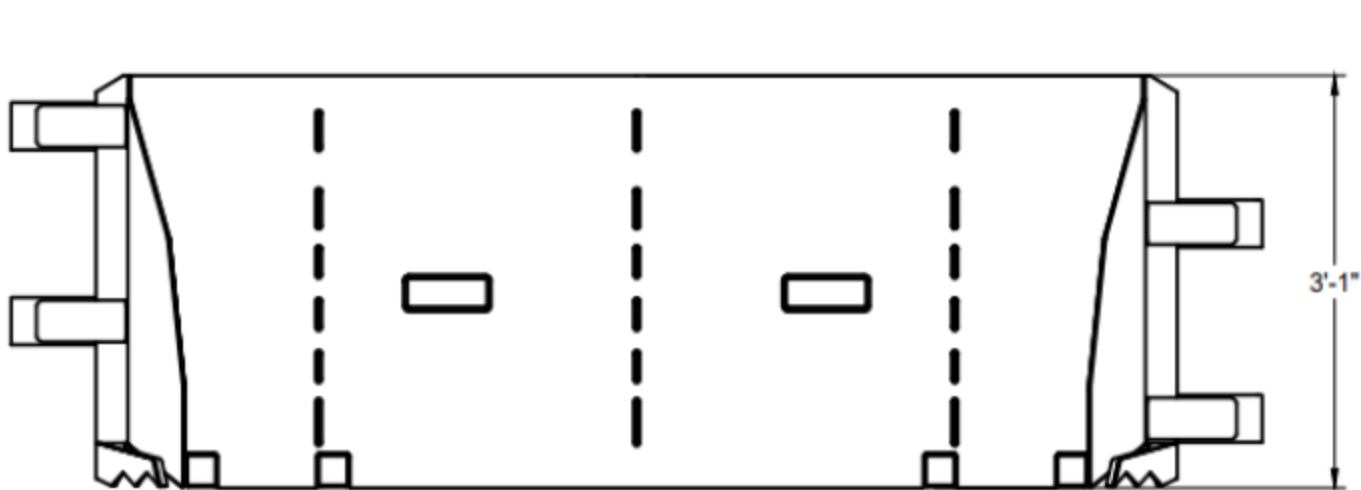

100% STEEL - 1/4" REINFORCED TUBING AND RIBS - HOT DIPPED GALVENIZED

Designed for Safe, Fast, Easy Barrier Deployment

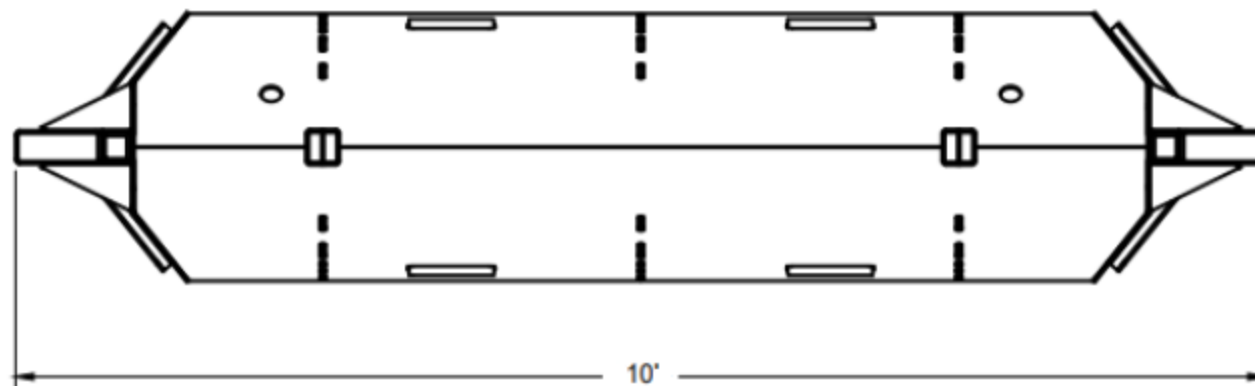

TRAILER SPECIFICATIONS:

- Max Load Capacity: 12,000 LB
- Max Barrier Capacity: 6
- Max Barrier Weight: 9,000 LB
- Load Angle: 3 Degrees

BARRIER SPECIFICATIONS: 1350 LBS

- Length: 10' Bottom Width: 2'
- Height: 3' 1" Top Width: 7"

Deployable wheels, spiked claws, tow bar, and barrier linking system. Two person transport, deploy and take-down. Industry leading affordability per linear foot. In stock and ready for fast shipment. Call for a free, no cost estimate today!



Barrier HQ



SBA WOSB
Woman Owned Small Business

For more information:
Call: (800) 930-0901
Email: sales@BarrierHQ.com
Web: www.BarrierHQ.com